

A

1

2

3



B

C

D

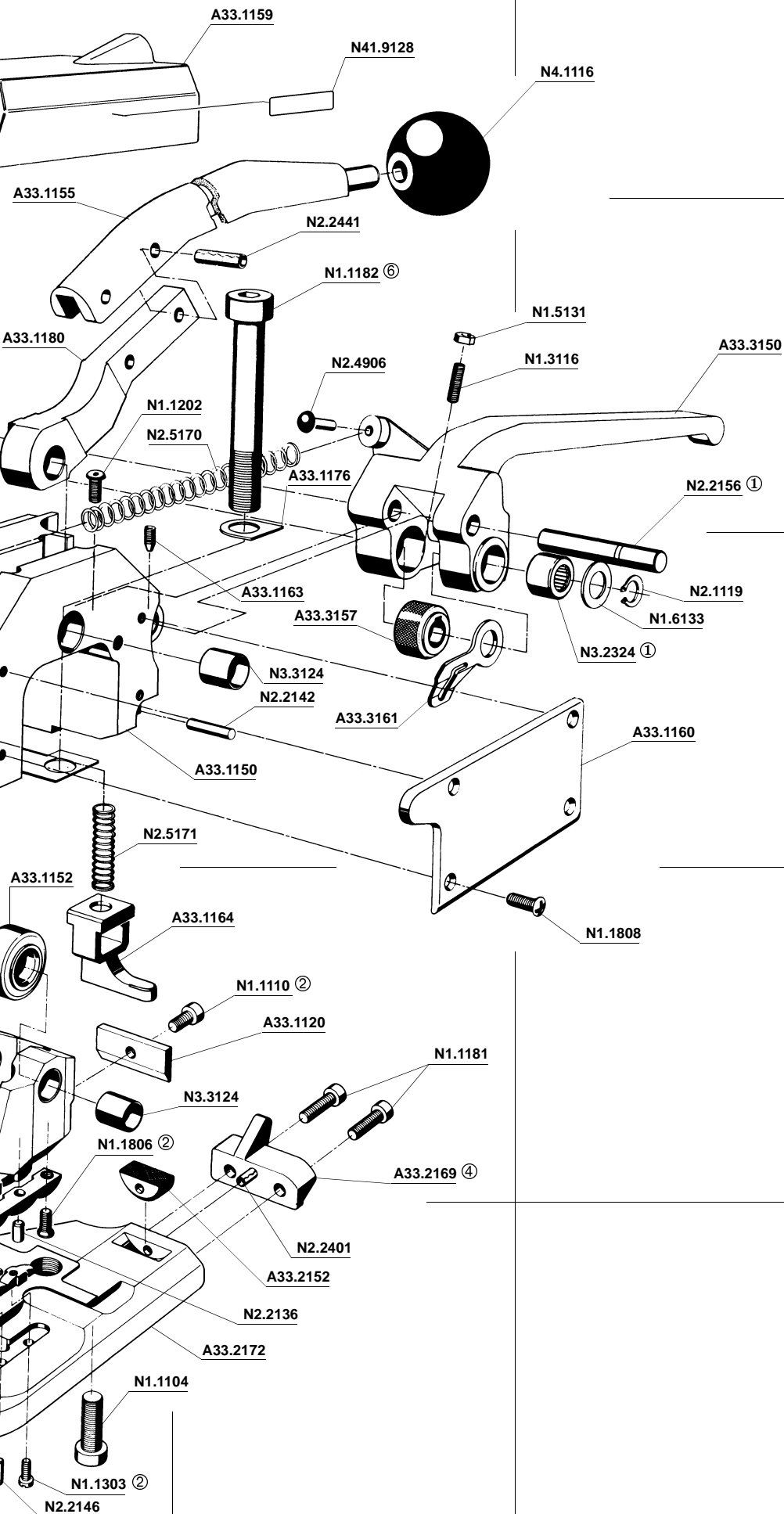
E



- ① ESSO Beacon 2
- ② Loctite 222
- ③ Loctite 243
- ④ Loctite 638
- ⑤  40 Nm
- ⑥  70 Nm
- ⑦ Compensation

7 SPARE PARTS LIST 13.2250.01

13.2250.01	A332/9.5/0.38-0.50		A332.0006.01		26.11.99	
Item-No.		in group	Pcs.	Description	Dimension	Field
A33.1120	*		1	SHEAR BLADE		D5
A33.1135	*		1	DIE HALF		E3
A33.1136	*		1	DIE HALF		E3
[A33.1150]			1	HOUSING		C5
A33.1151		A33.1191	1	DIE AND CUTTER SUPPORT		D3
A33.1152		A33.1191	1	ROLLER		D4
A33.1153		A33.1191	1	LINK		D4
A33.1155			1	SEALING HANDLE		A4
[A33.1157]			1	SHIM		C3
A33.1158			1	STOP		C3
A33.1159			1	COVER		A5
A33.1160			1	COVER		C6
A33.1161			1	BUSH		C3
A33.1163			1	SOCKET SET SCREW		C5
A33.1164			1	EJECTOR		D5
A33.1176			1	WASHER		B5
A33.1178			1	TRUNNION		B3
A33.1180			1	SEALING CAM		B4
[A33.1191]			1	DIE AND CUTTER SUPPORT		D3
A33.2120	*		1	PUNCH		E3
A33.2152	*		1	GRIPPER		E5
A33.2167			1	LIMIT BOLT		D3
A33.2169			1	STRAP STOP		D5
A33.2172			1	BASE PLATE		E5
A33.3111			2	CATCH PAWL		B2
A33.3124			2	RING HALF		B2
A33.3150			1	ROCKER		B6
A33.3151			1	TENSION HANDLE		A3
A33.3152			1	DRIVER		B2
A33.3153			1	LOCKING RING		B3
[A33.3154]			1	TENSION SHAFT		B2
A33.3157	*		1	TENSIONING WHEEL		C5
A33.3160	*		2	CATCH PAWL		B2
A33.3161			1	STRAP GUIDE		C5
N1.1104			1	SCREW	M8 X 20	E4
N1.1110			1	SCREW	M5 X 8	D5
N1.1165		A33.1150	1	SCREW	M8 X 10	B3
N1.1168			2	SCREW	M5 X 16	C3
N1.1181			2	SCREW	M5 X 12	D5
N1.1182			1	SCREW	M10 X 1 X 80	B5
N1.1183			1	SCREW	M8 X 1 X 80	B3
N1.1202			1	SCREW	M5 X 10	B4
N1.1210			1	SCREW	M6 X 25	B2
N1.1303			2	SCREW	M2 X 8	E4
N1.1806			4	SCREW	M4 X 10	D4+
N1.1808			4	SCREW	M4 X 10	D6
N1.3106			1	SOCKET SET SCREW	M5 X 6	E3
N1.3116			1	SOCKET SET SCREW	M5 X 25	B6
N1.3120			1	SOCKET SET SCREW	M12 X 12	C3
N1.3203			1	SOCKET SET SCREW	M4 X 8	C3
N1.5131			1	HEXAGON NUT	M5	B6

[] = Group

* = Wearing parts

13.2250.01	A332/9.5/0.38-0.50		A332.0006.01			26.11.99
Item-No.		in group	Pcs.	Description	Dimension	Field
N1.5907			1	HEXACON NUT	M6	B3
N1.6103			2	WASHER	5.3 X 9.5 X 1	C3
N1.6117			1	WASHER	8,4 X 17 X 1,6	B4
N1.6133			1	WASHER	12,2 X 22 X 1	C6
N2.1108			1	SECURITY RING	E20	B1
N2.1119			1	SECURITY RING	E10	C6
N2.2136		A33.1191	2	PARALLEL PIN	4 H6 X 10	E5
N2.2142			1	PARALLEL PIN	4 M6 X 28	C5
N2.2143		A33.1191	1	PARALLEL PIN	5 H6 X 16	D3
N2.2145			2	PARALLEL PIN	4 H6 X 18	E4
N2.2146			1	PARALLEL PIN	2 M6 X 10	E4
N2.2151		A33.1191	1	PARALLEL PIN	12 H6 X 39	D3
N2.2151			1	PARALLEL PIN	12 H6 X 39	B3
N2.2156			1	PARALLEL PIN	10 H6 X 58	B6
N2.2231			1	PARALLEL PIN	5 H8 X 50	C3
N2.2401			1	DOWEL PIN	3 X 10	E5
N2.2441			2	DOWEL PIN	6 X 20 MM	B5
N2.2603			1	GROOVED PIN	6 X 16	A3
N2.3201			1	WOODRUFF KEY	4 X 6,5 X 15,72	B2
N2.4902			2	HAMMER HEAD BOLT	1,85 X 4,76	B2
N2.4906			1	HAMMER HEAD BOLT	5,31 X 12,7	B5
N2.5154			4	PRESSURE SPRING	0.45 X 3.9 X 7	B2
N2.5170			1	PRESSURE SPRING	2 X 9.8 X 96	B4
N2.5171			1	PRESSURE SPRING	1 X 8 X 26	C4
N2.5606			1	CUP SPRING	40X20.4X1	B2
N2.5807			1	TORSION SPRING		C3
N3.2324			1	NEEDLE BUSH		C6
N3.2329			1	NEEDLE BUSH		B3
N3.3124		A33.1191	2	SLIDE-BEARING		D4+
N3.3124			2	SLIDE-BEARING		B3+
N41.9128			1	ADHESIVE LABEL		A5
N41.9130			1	LABEL	A332	C2
N4.1116			2	GRIP BALL		A3+

[] = Group

* = Wearing parts